

# SOFTWARE USER MANUAL

## Earth Observation Software. Orbit and Attitude Adapter Tool

**Code:**  
**Issue:** 1.2  
**Approval Date:** <01/12/2020>  
**Confidentiality Level:**

**Prepared by:** Juan José Borrego  
**Reviewed by:** Carlos Villanueva  
**Approved by:** Carlos Villanueva

Approval Signature:

This page intentionally left blank

## Document Status Log

Issue	Section	Change Description	Date
1.0		First Release	07/12/2016
1.1		<ul style="list-style-type: none"> <li>- Configuration file format updated (rotation angles specification)</li> <li>- Allow processing the input data from memory</li> <li>- Add inconsistencies check when processing NAVATT packages</li> <li>- Quaternion generation according to EOCFI convention</li> <li>- Time initialization based on IERS Bulletins enabled</li> <li>- Support for all the missions supported by EOCFI</li> </ul>	21/06/2019
1.2		<ul style="list-style-type: none"> <li>- EOCFI updated to latest version 4.20</li> <li>- DFDL4S updated to latest version 1.6.1</li> <li>- Support for all the missions supported by EOCFI</li> <li>- Examples for Sentinel-3 updated for the latest DFDL4S schemas</li> <li>- New example for MetPpSG</li> </ul>	01/12/2020

## Table of Contents

<b>1. INTRODUCTION</b>	<b>5</b>
<b>1.1. Purpose</b>	<b>5</b>
<b>1.2. The Orbit Attitude Adapter Tool</b>	<b>6</b>
<b>1.3. Acronyms and Abbreviations</b>	<b>6</b>
<b>1.4. Definitions</b>	<b>6</b>
<b>2. RELATED DOCUMENTS</b>	<b>7</b>
<b>2.1. Applicable Documents</b>	<b>7</b>
<b>2.2. Reference Documents</b>	<b>7</b>
<b>3. Installation</b>	<b>8</b>
<b>3.1. Requirements</b>	<b>8</b>
<b>3.2. Installation instruction</b>	<b>8</b>
<b>4. Usage GUIDE</b>	<b>9</b>
<b>4.1. Executable program</b>	<b>9</b>
4.1.1. Example	9
<b>4.2. Library Usage</b>	<b>9</b>
4.2.1. Using predefined parsers.	9
4.2.2. Custom parser	10
4.2.3. Examples	11
4.2.3.1. Example 1	11
4.2.3.2. Example 2	11
4.2.3.3. Example 3 (DEPRECATED)	12
4.2.3.4. Example 4	12
<b>5. Configuration file description</b>	<b>13</b>
<b>5.1. Input Configuration</b>	<b>13</b>
5.1.1. DFDL4S Parser configuration	15
<b>5.2. Output Configuration</b>	<b>17</b>
<b>6. User interface</b>	<b>19</b>

## List of Tables

Table 1: Applicable documents .....	7
Table 2: Reference documents .....	7

## 1. INTRODUCTION

### 1.1. Purpose

The Earth Observation Mission Software (EOCFI SW) is a set of multiplatform software libraries which are made available free of charge to any user involved in supporting the Earth Observation missions preparation and exploitation. The EOCFI SW is typically used in Ground Segment operational facilities and in tools developed by ESA and their partners for Earth Observation Missions.

The EOCFI SW libraries provide functionalities for a wide range of high-level computations: orbit (e.g. interpolation, propagation using different models); attitude (e.g. interpolation, attitude law); target pointing (e.g. direct/inverse geo-location with DEM); geometric properties of calculated targets; instrument swath computation and zone intersection; zone/station visibility events; observation opportunities for instruments (time segments and coverage). Low level functions are also provided, for example to support for several file formats read/write; co-ordinates / time transformations.

The main inputs to the above functions are related to the satellite state. This information can be originated from different sources i.e.: models (e.g. propagators) implemented within the EOCFI SW itself; simulations or dedicated services (e.g. POD); S/C telemetry.

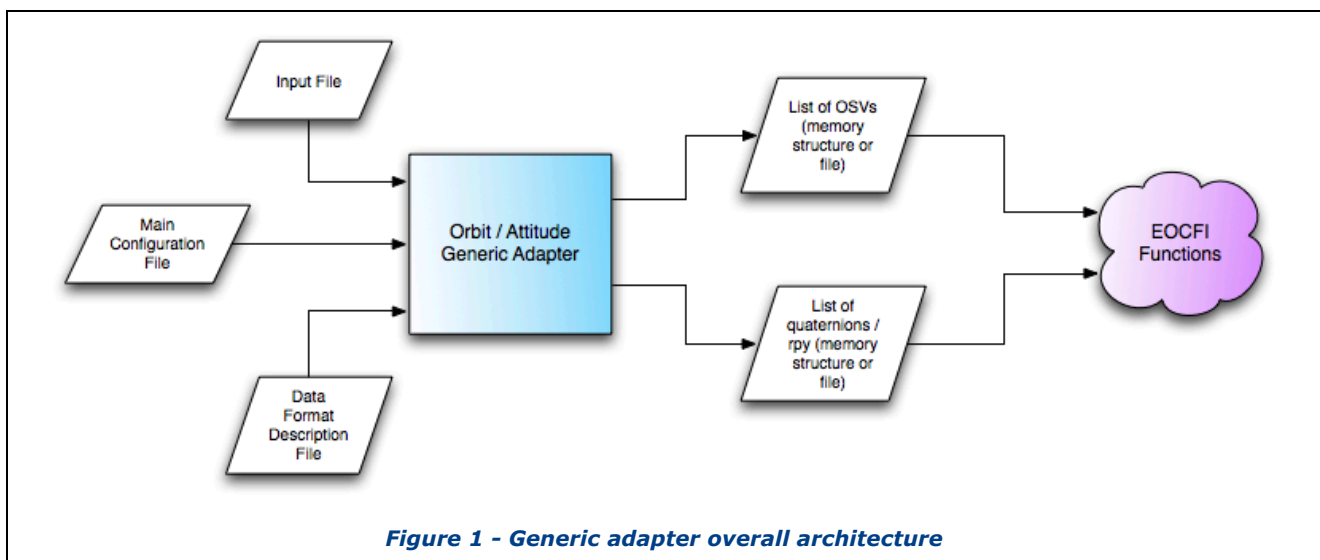

Data required to initialise the satellite state is typically:

- a list of position and velocity at given times (OSVs);
- a list of attitude parameters at a given times (e.g. quaternions, roll-pitch-yaw angles).

Such inputs can be passed to EOCFI functions via dedicated data structures or files. The EOCFI SW supports several types of files (see [RD 2]) and, in particular, orbit and attitude files compliant with the EO GS File Format Standard (see [RD 3]). However, very often such inputs may be made available using formats that are not directly supported by the EOCFI SW. For example, downlinked OSVs and quaternions are received within Instrument Source Packets (ISPs) whose format is mission dependent. Normally, for each specific format, a dedicated decoder needs to be implemented. The Orbit Attitude adapter tool performs the translation between formats.

The Orbit Attitude adapter tool / API receives as input:

- Data (i.e. files or software in memory) containing orbit and attitude;
- Optionally, data format description in e.g. DFDL language (DFDL is "a modeling language for describing general text and binary data in a standard way", see [RD 4]);
- A main configuration file that includes the required configuration parameters (for example the parser that, for the DFDL language is the DFDL4S parser, see [RD 5]).

And generating as output OSV and quaternions/rpy as lists in memory structures or files that can be ingested by EOFCFI functions.

## 1.2. The Orbit Attitude Adapter Tool

The Orbit Attitude Adapter tool consists in:

- An executable program that can be called from a command prompt window.
- A JAVA library (a jar file ) that can be used in a JAVA program

The executable program allows parsing input data files using a predefined parser that is already implemented in the tool.

The JAVA library allows parsing the input data files using either a predefined parser or a "CUSTOM" parser that has to be implemented by the user.

The current version allows the following predefined parsers:

- DFDL4S parser.

The following sections of this document describe how to install and use the tool:

- Section 3 describes the installation instructions.
- Section 4 describes how to use the program and/or the JAVA library.
- Section 5 describes the main configuration file to be used by the tool.
- Section 6 describes the API for the JAVA library.

## 1.3. Acronyms and Abbreviations

TBW

## 1.4. Definitions

TBW

## 2. RELATED DOCUMENTS

### 2.1. Applicable Documents

The following table specifies the applicable documents that shall be complied with during project development.

*Table 1: Applicable documents*

Reference	Code	Title	Issue
[AD 1]			
[AD 2]			

### 2.2. Reference Documents

The following table specifies the reference documents that shall be taken into account during project development.

*Table 2: Reference documents*

Reference	Title	Issue
[RD 1]	EOCFI documentation main page, <a href="http://eop-cfi.esa.int/index.php/mission-cfi-software/eocfi-software/branch-4-x/eocfi-v4x-documentation">http://eop-cfi.esa.int/index.php/mission-cfi-software/eocfi-software/branch-4-x/eocfi-v4x-documentation</a>	
[RD 2]	"Earth Observation Mission CFI Software – Data Handling User Manual", v4.10, <a href="http://eop-cfi.esa.int/Repo/PUBLIC/DOCUMENTATION/CFI/EOCFI/BRANCH_4X/4.10/C-Docs/SUMs/DataHandlingSUM_v4_10.pdf">http://eop-cfi.esa.int/Repo/PUBLIC/DOCUMENTATION/CFI/EOCFI/BRANCH_4X/4.10/C-Docs/SUMs/DataHandlingSUM_v4_10.pdf</a>	
[RD 3]	"Earth Observation Ground Segment File Format Standard" <a href="http://eop-cfi.esa.int/Repo/PUBLIC/DOCUMENTATION/SYSTEM_SUPPORT_DOCS/PE-TN-ESA-GS-0001%20EO%20GS%20File%20Format%20Standard%203.0.pdf">http://eop-cfi.esa.int/Repo/PUBLIC/DOCUMENTATION/SYSTEM_SUPPORT_DOCS/PE-TN-ESA-GS-0001%20EO%20GS%20File%20Format%20Standard%203.0.pdf</a>	3
[RD 4]	Wikipedia: "Data Format Description Language", <a href="https://en.wikipedia.org/wiki/Data_Format_Description_Language">https://en.wikipedia.org/wiki/Data_Format_Description_Language</a>	
[RD 5]	DFDL4S Project, <a href="http://eop-cfi.esa.int/index.php/applications/dfdl4s">http://eop-cfi.esa.int/index.php/applications/dfdl4s</a>	

## 3. INSTALLATION

### 3.1. Requirements

Software requirements:

- Java 1.8
- DFDL4S libraries v1.6.1.
- EOCFI libraries v4.20

### 3.2. Installation instruction

To install the library and the executable program just unzip the distribution archive EO\_ADAPTER-X.X-JAVA-OS.zip (for example EO\_ADAPTER-1.0-JAVA-LINUX64.zip) into an installation directory. The folder structure resultant of this action is as follows:

- EO\_ADAPTER: main folder containing the LICENSE and README files.
- EO\_ADAPTER/bin: Adapter tool ready to use from a command line.
- EO\_ADAPTER /example: Ready-to-use example with a standalone Java program (including a script to compile and run).
- EO\_ADAPTER/files: It contains the schema and template for the configuration file.
- EO\_ADAPTER/lib: The EO Orbit and Attitude adapter library + required external libraries (cots)
- README and TERMS\_AND\_CONDITIONS.TXT files



## 4. USAGE GUIDE

### 4.1. Executable program

An executable (in *installation\_folder/bin/EoOrbAttAdapter\_CLI.sh*) program is provided to parse the data files to EOFCI orbit and attitude files.

This program can be called from a command prompt terminal in the following way:

```
>EoOrbAttAdapter_CLI.sh [ARGUMENTS]
[ARGUMENTS] list could be:
-help                : Shows this help
-v                  : Shows library versions
-cfg "configuration_file" : Input configuration file (Mandatory)
-df "input_data_files"  : Input data files. (Optional)
                        Several files can be provided separated by a blank space. If
                        not provided, the data file will be taken from the
                        "configuration file"
-of "output_orbit_file" : Output orbit file. (Optional)
                        If not provided, the output orbit file name will be taken
                        from the "configuration file"
-af "output_attitude_file": Output orbit file. (Optional)
                        If not provided, the output orbit file name will be taken
                        from the "configuration file"
-disableOrbitParser   : Orbit parser disabled (Optional).
                        Orbit file will not be created.
-disableAttitudeParser : Attitude parser disabled (Optional).
                        Attitude file will not be created.
```

#### 4.1.1. Example

```
> EoOrbAttAdapter_CLI.sh -cfg ./my_configuration_file.xml -df data/ISPDData.dat
```

### 4.2. Library Usage

In order to decode a data file using the JAVA library, the user can create its own parser (CUSTOM) or can use the predefined parsers. The parser to be used is set in the configuration file.

#### 4.2.1. Using predefined parsers.

For using a predefined parser, the following steps should be given:

1. Import the tool package:

```
import EoOrbAttAdapter.*;
```

2. [OPTIONAL]

Get the configuration for the tool (class **AdpMainConfiguration**). Nominally the configuration is loaded from file (*adapter\_configuration\_file*. See section 5), although it could be set manually (see the API for **AdpMainConfiguration** in section 6).

```
AdpMainConfiguration adpConfig = new AdpMainConfiguration();
```

```
adpConfig.loadMainConfiguration("adapter_configuration_file");
```

3. Create the adapter (**EoOrbAttAdapter** class) and set the configuration. The configuration can be set with the **AdpMainConfiguration** object if the step 2 was done, if not, the configuration can be set directly with the `adapter_configuration_file`:

```
EoOrbAttAdapter myAdapter = new EoOrbAttAdapter();
```

```
myAdapter.setMainConfiguration(adpConfig);
```

or

```
myAdapter.setMainConfiguration("./adp_configuration_file.xml");
```

4. Parse the data files or the data in memory. The data file can be given as an input parameter or if it is not specified, the data file will be the given in the **AdpMainConfiguration** object. Note that several data files can be parsed so that all data will be joined together to be returned afterwards as a single file:

```
myAdapter.parse(); // parse the file in the AdpMainConfiguration object
```

or

```
myAdapter.parse(inputDataFile_1); // inputDataFile_1 = path + file name for 1st file
```

```
myAdapter.parse(inputDataFile_2); // inputDataFile_2 = path + file name for 2nd file
```

```
myAdapter.parse(inputDataFile_3); // inputDataFile_3 = path + file name for 3rd file
```

or

```
myAdapter.parse(inputData); // inputData is data stored as an array of bytes (byte[])
```

...

5. Get the orbit/attitude data and/or write the files to disk.

```
OrbitFile myOrbitFile = myAdapter.getOrbitData();
```

```
AttFile myAttFile = myAdapter.getAttitudeData();
```

```
myAdapter.writeOrbitDataToFile("./output_orbit_file.xml");
```

```
myAdapter.writeAttitudeDataToFile("./output_att_file.xml");
```

if the filename is not provided in the writing methods, the file name is taken from the **AdpMainConfiguration** object.

#### **4.2.1.1. For an example of a predefined parser see Example 1 and Example 3 (DEPRECATED)**

Example 4.

#### **4.2.2. Custom parser**

In order to use a custom parser, the user has to implement the following JAVA classes:

- A Class *UserParser*, that inherits the class **AdpDefaultParser**. This class has to override the abstract methods:
  - o **Parse(String dataFile)**: This method is in charge of reading the data file and filling the output objects with the data.
  - o **Parse(byte[] dataArr)**: This method is in charge of parsing the input data array and filling the output objects with that data.

For an example of a custom parser, see the class *MyParser* in Example 2.

- A Class *UserParserConfiguration* that inherits the class **AdpParserConfiguration**. This class overrides the method **loadFromFile**. This method reads the configuration file, that is inside the path:

/Earth\_Explorer\_File/Data\_Block/Orbit\_Attitude\_Adapter\_Configuration/Input\_Configuration/  
Parser\_Configuration

If the parser does not need any parameter from configuration, the method could be empty.

For an example of a custom parser configuration, see the class MyParserConfiguration in Example 2.

Once the custom parser is defined, the following steps should be given:

1. Import the tool package:

```
import EoOrbAttAdapter.*;
```

2. Set the adapter main configuration with a file:

- 2.1. Create the custom parser configuration

```
UserParserConfiguration parserConfig = new UserParserConfiguration();
```

- 2.2. Create the custom parser and set the configuration

```
UserParser myTextParser = new UserParser();
```

```
myTextParser.setParserConfiguration(parserConfig);
```

- 2.3. Create the adapter and set parser and configuration with an input file

```
EoOrbAttAdapter myAdapter = new EoOrbAttAdapter();
```

```
myAdapter.setParser(myTextParser);
```

```
myAdapter.setMainConfiguration("./adp_configuration_file.xml");
```

3. Continue with steps 4 and 5 as for the predefined parser (section 4.2.1).

For an example of a custom parser see Example 2.

### 4.2.3. Examples

Several examples are provided in *installation\_folder/examples/example\_#* (#=1,2)

The explanations of the examples are inside the .java files.

#### 4.2.3.1. Example 1

This example consists in parsing a data file with DF4S format. For details, see the README file inside the example directory.

For running the example:

- Go to the example directory:  
>cd *installation\_folder/examples/example\_1*
- Run the script *example\_compile\_and\_run.sh*. This script compiles the example program (*EoAdapterDfd4sExample.java*) and executes it.  
>cd *./example\_compile\_and\_run.sh*

#### 4.2.3.2. Example 2

This example consists in parsing a text file using a parser implemented by the user (Custom Parser). For details, see the README file inside the example directory.

For running the example:

- Go to the example directory:  
>cd *installation\_folder/examples/example\_2*
- Run the script *example\_compile\_and\_run.sh*. This script compiles the example program (*EoAdapterCustomExample.java*) and executes it.  
>cd *./example\_compile\_and\_run.sh*

#### **4.2.3.3. Example 3 (DEPRECATED)**

#### **4.2.3.4. Example 4**

This example consists in parsing a data in memory with DFDL4S format. For details, see the README file inside the example directory.

For running the example:

- Go to the example directory:  
`>cd installation_folder/examples/example_4`
- Run the script `example_compile_and_run.sh`. This script compiles the example program (`EoAdapterDfdl4sExample.java`) and executes it.  
`>cd ./example_compile_and_run.sh`

#### **4.2.3.5. Example 5**

This example consists in parsing a data file for MetOpSG with DFDL4S format. For details, see the README file inside the example directory.

For running the example:

- Go to the example directory:  
`>cd installation_folder/examples/example_5`
- Run the script `example_compile_and_run.sh`. This script compiles the example program (`EoAdapterDfdl4sExample.java`) and executes it.  
`>cd ./example_compile_and_run.sh`

## 5. CONFIGURATION FILE DESCRIPTION

Operations of the adapter are controlled by a main configuration file. This configuration file is compliant with Earth Observation file format standard. The following defines the sections enclosed in the Data Block relevant to the adapter configuration (i.e. header information is omitted).

```
<Data_Block type="xml">
  <Orbit_Attitude_Adapter_Configuration>
    <Input_Configuration>
      <Default_Values>...</Default_Values>
      <Parser_Configuration type="DFDL4S" version="1.4">...</Parser_Configuration>
      <Common>...</Common>
      <Checks>...</Checks>
    </Input_Configuration>
    <Output_Configuration>
      <Orbit>...</Orbit>
      <Attitude>...</Attitude>
      <Common>...</Common>
    </Output_Configuration>
  </Orbit_Attitude_Adapter_Configuration>
</Data_Block>
```

**Figure 2 – Main Configuration File skeleton**

The file is composed by a node named Orbit\_Attitude\_Adapter\_Configuration that contains Input\_Configuration and Output\_Configuration nodes:

### 5.1. Input Configuration

The <Input\_Configuration> tag contains the following data:

- Default Values: contains the tag Input\_Data\_Filename, that defines a default filename for the input data file. This file name is used only in case that the user did not provide explicitly a data file name in the tool inputs.

```
<Default_Values>
  <Input_Data_Filename>...</Input_Data_Filename>
</Default_Values>
```

**Figure 3 – Main Configuration File: Input configuration, Default\_Values section**

- Parser Configuration: contains specific data for the parser configuration. In general the parser configuration tag has the following structure:

```
<Parser_Configuration type="..." version="...">
  <Schema_Filename>...</Schema_Filename>
  <Orbit>...</Orbit>
  <Attitude>...</Attitude>
</Parser_Configuration>
```

**Figure 4 – Main Configuration File: Input configuration, Parser\_Configuration section**

The content of the tags <Orbit> and <Attitude> are different depending on parser to be used. For the custom parser, it can be filled with tags chosen by the users to their needs. For the predefined parsers (as for the DFDL4S) the data structure is fixed (see the following subsections).

For the custom parser, the reading of the tags inside <Orbit> and <Attitude> has to be implemented by the user. For this, the user has to create a class that implements the interface for AdpParserConfiguration. This interface contains a method (loadFromFile) where the <Parser\_Configuration> can be read.

- Common: This section contains:
  - The Model section: it can be used to specify the model used by EOCFI computations. Only the DEFAULT model is supported;

- The Time\_correlations section is used to define the relation amongst UTC, TAI, UT1, GPS. The method used depends on the type attribute:
  - FIXED\_CORRELATIONS: the fields UTC\_UT1, UTC\_TAI, UTC\_GPS will be used (e.g. UTC\_UT1 = UTC time – UT1 time in seconds).
  - NONE: All time correlations will be set to 0 (no time correlations).
  - For the following types, the time correlations are initialized using the set of input files (They have to be provided ordered by time). The type can be any of these:
    - FILE: One input time correlation file that will be detected automatically
    - IERS\_B\_PREDICTED: IERS Bulletin B table 1 (predicted)
    - IERS\_B\_RESTITUTED: IERS Bulletin B table 2 (restituted)
    - FOS\_PREDICTED: FOS Predicted orbit files
    - FOS\_RESTITUTED: FOS Restituted orbit files
    - DORIS\_PRELIMINARY: DORIS preliminary orbit files
    - DORIS\_PRECISE: DORIS precise orbit files
    - DORIS\_NAVIGATOR: DORIS navigator files.
    - OSF: One orbit scenario file.
    - IERS\_A\_ONLY\_PREDICTION: IERS bulleting A (prediction table)
    - IERS\_A\_PREDICTION\_AND\_FORMULA: (prediction table and extrapolation formula)
    - IERS\_B\_AND\_A\_ONLY\_PREDICTION: IERS bulletin B and prediction table from bulletin A (the files have to be provided in this order, first the bulletin B and then the bulletin A)

```

<Common>
  <Model type="..."\>
    <Time_Correlations type="...">
      <Time_Correlations_File>...</Time_Correlations_File>
      <Time_Correlations_File>...</Time_Correlations_File>
      <Default_Values>
        <UTC_UT1 unit="s">...</UTC_UT1>
        <UTC_TAI unit="s">...</UTC_TAI>
        <UTC_GPS unit="s">...</UTC_GPS>
      </Default_Values>
    </Time_Correlations>
  </Common>

```

**Figure 5 – Main Configuration File: Input configuration, Common section**

- Checks: This section is optional (new from version 1.1). The parsed orbit and attitude data will be checked to look for different incongruent data, according to the following parameters. Those orbit/attitude records suspicious of wrong data can be reported.
  - Orbit\_Checks:
    - Time gaps validation:
      - Maximum\_Gap: maximum allowed time interval between orbit records
      - Time\_Step: expected time interval between records.
      - Duplicated\_Threshold: Two records will be considered to be duplicated if they differ less than this value.
      - Time\_Step\_Threshold: Threshold to consider than the time interval is kept within its expected regular interval.
  - Attitude\_Checks:
    - Time gaps validation:
      - Maximum\_Gap: maximum allowed time interval between records
      - Time\_Step: expected time interval between records.
      - Duplicated\_Threshold: Two records will be considered to be duplicated if they differ less than this value.
      - Time\_Step\_Threshold: Threshold to consider than the time interval is kept within its expected regular interval.

```

<Checks>
  <Orbit_Checks>
    <TimeGapValidation>
      <Maximum_Gap units="s">5</Maximum_Gap>
      <Time_Step units="s">1</Time_Step>
      <Duplicated_Threshold units="s">0.1</Duplicated_Threshold>

```

```

        <Time_Step_Threshold units="s">0.05</Time_Step_Threshold>
    </TimeGapValidation>
</Orbit_Checks>
<Attitude_Checks>
    <TimeGapValidation>
        <Maximum_Gap units="s">2</Maximum_Gap>
        <Time_Step units="s">1</Time_Step>
        <Duplicated_Threshold units="s">0.001</Duplicated_Threshold>
        <Time_Step_Threshold units="s">0.05</Time_Step_Threshold>
    </TimeGapValidation>
</Attitude_Checks>
</Cheks>

```

- **Figure 6 – Main Configuration File: Input configuration, Checks section**

### 5.1.1. DFDL4S Parser configuration

As described above, the parser configuration tag contains three sections: the <Schema\_Filename>, the <Orbit> and the <Attitude>, being the <Orbit> and the <Attitude> the specifics parts. For the DFDL4S are as follows:

```

<Parser_Configuration type="DFDL4S" version="1.4">
    <Schema_Filename>...</Schema_Filename>
    <Orbit status="enabled">...</Orbit>
        <Mapping type="OSV">
            <Time_Reference>...</Time_Reference>
            <Time>...</Time>
            <Reference_Frame>...</Reference_Frame>
            <X correction_factor="..">...</X>
            <Y correction_factor="..">...</Y>
            <Z correction_factor="..">...</Z>
            <VX correction_factor="..">...</VX>
            <VY correction_factor="..">...</VY>
            <VZ correction_factor="..">...</VZ>
            <Orbit_number default="true">...</Orbit_number>
            <Quality default="true">...</Quality>
            <Default_Values>
                <Quality>...</Quality>
                <Orbit_Number type="OSF">
                    <OSF_Filename>...</OSF_Filename>
                </Orbit_Number>
            </Default_Values>
        </Mapping>
    </Orbit>
    <Attitude status="enabled">
        <Mapping>
            <Mapping_Quat>
                <Time_Reference>..</Time_Reference>
                <Time>...</Time>
                <Reference_Frame>...</Reference_Frame>
                <Q1 correction_factor="..">...</Q1>
                <Q2 correction_factor="..">...</Q2>
                <Q3 correction_factor="..">...</Q3>
                <Q4 correction_factor="..">...</Q4>
            </Mapping_Quat>
        </Mapping>
        <Inverse_Transformation></Inverse_Transformation>
        <Axis_Mapping>
            <>...</X>
            <Y>...</Y>
            <Z>...</Z>
        </Axis_Mapping>
    </Attitude>
</Parser_Configuration >

```

**Figure 7 – Main Configuration File: Input configuration, Parser\_Configuration section for DFDL4S parser Attitude defined with quaternions.**

or

```

<Parser_Configuration type="DFDL4S" version="1.4">
  <Schema_Filename>...</Schema_Filename>
  <Orbit status="enabled">...</Orbit>
    <Mapping type="OSV">
      <Time_Reference>...</Time_Reference>
      <Time>...</Time>
      <Reference_Frame>...</Reference_Frame>
      <X correction_factor="..">...</X>
      <Y correction_factor="..">...</Y>
      <Z correction_factor="..">...</Z>
      <VX correction_factor="..">...</VX>
      <VY correction_factor="..">...</VY>
      <VZ correction_factor="..">...</VZ>
      <Orbit_number default="true">...</Orbit_number>
      <Quality default="true">...</Quality>
      <Default_Values>
        <Quality>...</Quality>
        <Orbit_Number type="OSF">
          <OSF_Filename>...</OSF_Filename>
        </Orbit_Number>
      </Default_Values>
    </Mapping>
  </Orbit>
  <Attitude status="enabled">
    <Mapping>
      <Mapping_Angles>
        <Time_Reference>..</Time_Reference>
        <Time>...</Time>
        <Reference_Frame>...</Reference_Frame>
        <Pitch correction_factor="..">...</Pitch>
        <Roll correction_factor="..">...</Row>
        <Yaw correction_factor="..">...</Yaw>
      </Mapping_Angles>
    </Mapping>
    <Inverse_Transformation></Inverse_Transformation>
    <Axes_Mapping>
      <X>...</X>
      <Y>...</Y>
      <Z>...</Z>
    </Axes_Mapping>
  </Attitude>
</Parser_Configuration >
  
```

**Figure 8 – Main Configuration File: Input configuration, Parser\_Configuration section for DFDL4S parser. Attitude defined with rotation angles**

The Orbit section in the input configuration contains:

- Attribute *status*: it can be "enabled" or "disabled". When it is disabled, the orbit data will not be parsed.
- The Mapping section: it defines the correspondence between items defining an orbit and elements in the DFDL4S schema. The type of mapping is defined by the *type* attribute (currently only *OSV* is allowed). The elements are described as a path from the root node. In particular:
  - *Time\_Reference*: either TAI, UTC, UT1 or N/A; It is the time reference for the read time;
  - *Time*: the OSV epoch;
  - *Reference\_Frame*: Reference frame of the OSV (BAR\_MEAN\_2000, HEL\_MEAN\_2000, GEO\_MEAN\_2000, MEAN\_DATE, TRUE\_DATE, EARTH\_FIXED, BAR\_MEAN\_1950, QUASI\_MEAN\_DATE, PSE\_TRUE\_DATE, PSEUDO\_EARTH\_FIXED);
  - *X, Y, Z*: position. The *correction\_factor* attribute defines a correction to be applied to the data in order to have the position consistent to EOFCFI conventions (i.e. expressed in meters);
  - *VX, VY, VZ*: position. The *correction\_factor* attribute defines a correction to be applied to the data in order to have the velocity consistent to EOFCFI conventions (i.e. expressed in meters/sec);
  - *Orbit\_Number*: Orbit number of the OSV. It contains the attribute *default*(=true or false).When *default* is true, the orbit number is not read from the file with the path but computed with an OSF specified below, in the *Default\_Values* section.



- Quality: quality value of the OSV; It contains the attribute *default* (=true or false). When *default* is true, the *quality* is not read from the path specified, it will have the value specified below, in the *Default\_Values* section.
- *Default\_Values*: this section is used when the attribute default is set to true. It contains:
  - A default value of *Orbit\_Number* (if its attribute *type* is set to "OSF" (currently the only value allowed), the Orbit number will be calculated using an Orbit Scenario File).
  - A default value for Quality; All OSV will have the same quality value.

The Attitude section has a structure similar to the Orbit section:

- Attribute *status*: it can be "enabled" or "disabled". When it is disabled, the attitude data will not be parsed.
- The Mapping section: it defines the correspondence between items defining an attitude and elements in the DFDL4S schema. The type of mapping is defined by the *type* attribute, it could be "Quaternions" or "Angles".

For Quaternions:

- *Time\_Reference*: either TAI, UTC, UT1 or N/A; It is the time reference for the read time;
- *Time*: the quaternion epoch;
- *Reference\_Frame*: Reference frame that is the origin frame for the rotation represented by the quaternions (BAR\_MEAN\_2000, HEL\_MEAN\_2000, GEO\_MEAN\_2000, MEAN\_DATE, TRUE\_DATE, EARTH\_FIXED, BAR\_MEAN\_1950, QUASI\_MEAN\_DATE, PSE\_TRUE\_DATE, PSEUDO\_EARTH\_FIXED);
- *Q1, Q2, Q3, Q4*: Path for the Quaternions elements. Quaternions numbering follows the EOCFI conventions (i.e. Q4 is the real component).

For Angles:

- *Time\_Reference, Time and Reference\_Frame*: as defined for the quaternions.
- *Pitch, Roll, Yaw*: Path for the rotation angle elements.
- *Inverse\_Transformation*: Optional parameter. When exits, it means that the quaternions/angles represents the rotation from the satellite attitude frame to the *Reference\_Frame*.
- *Axis\_Mapping*: Attitude data represent a transformation from two co-ordinate systems, for example GM2000 to satellite attitude frame. Axes of this attitude frame are not necessarily defined according to EOCFI conventions. The *Axes\_Mapping* section provides the correspondence between co-ordinate system axes in EOCFI conventions and input data. For example: <X>Y\_positive</X> means that the EOCFI X axis is the Y positive axis in the data convention.

## 5.2. Output Configuration

The <Output\_Configuration> tag has the following tags (see Figure 9):

- Orbit: contains the configuration data required for the output orbit file.
- Attitude: contains the configuration data required for the output attitude file.
- Common: Contains the tag <Satellite\_Id> with the satellite/mission name.

The <Orbit> and <Attitude> tags have a similar structure. The content is as follows:

- Attribute Type: it can be:
  - EOCFI\_FILE: the output is written to a EOCFI compliant file.
- Default\_Filename: this is the filename used in case no filename is provided via the adapter interface. If the Default\_Filename field is empty and no output file is specified via the adapter interface, the file name will be generated as per File Format Standard.
- Time\_Reference: Default Time reference. (Allowed values: TAI, UTC, UT1, N/A).
- Reference\_Frame: For the orbit file, it is the reference frame of the state vectors. For the attitude file, it is the reference frame for the source inertial frame. (Allowed values: BAR\_MEAN\_2000, HEL\_MEAN\_2000, GEO\_MEAN\_2000, MEAN\_DATE, TRUE\_DATE, EARTH\_FIXED, BAR\_MEAN\_1950, QUASI\_MEAN\_DATE, PSE\_TRUE\_DATE, PSEUDO\_EARTH\_FIXED)
- Target\_Frame (only for Attitude): Attitude target frame (Allowed values: Sat\_Nominal\_Attitude, Sat\_Attitude, Instr\_Attitude).
- Header\_Configuration defines the header fields as defined by the File Format Standard that cannot be generated automatically by the adapter:

- Notes
- File\_Class
- File\_Type
- File\_Version
- Source/System

```

<Output_Configuration>
  <Orbit type="EO_FILE">
    <Default_Filename>...</Default_Filename>
    <Time_Reference>...</Time_Reference>
    <Reference_Frame>...</Reference_Frame>
    <Header_Configuration>
      <Notes>...</Notes>
      <Mission>...</Mission>
      <File_Class>...</File_Class>
      <File_Type>...</File_Type>
      <File_Version>...</File_Version>
      <Source>
        <System>...</System>
      </Source>
    </Header_Configuration>
  </Orbit>

  <Attitude type="EO_FILE">
    <Default_Filename>...</Default_Filename>
    <Time_Reference>...</Time_Reference>
    <Reference_Frame>...</Reference_Frame>
    <Target_Frame>...</Target_Frame>
    <Header_Configuration>
      <Notes>...</Notes>
      <Mission>...</Mission>
      <File_Class>...</File_Class>
      <File_Type>...</File_Type>
      <File_Version>...</File_Version>
      <Source>
        <System>...</System>
      </Source>
    </Header_Configuration>
  </Attitude>

  <Common>
    <Satellite_Id>...</Satellite_Id>
  </Common>
</Output_Configuration>

```

**Figure 9 – Main Configuration File: Output configuration**

---

## **6. USER INTERFACE**

The Orbit Attitude Adapter tool library consists in a set of JAVA classes. All these classes are included in the package EoOrbAttAdapter. The API of the library can be found in the HTML documentation: <http://eop-cfi.esa.int/index.php/mission-cfi-software/eo-adapter/adapter-documentation>